CHECK•LINE®
BY ELECTROMATIC

TI-45NA

THICKNESS GAUGE



TABLE OF CONTENTS

1.0 Introduction	2
1.1 Delivery list	
1.2 Precautions	
2.0 Overview	5
2.1 Main unit	
2.2 LCD display	
2.3 Operation panel	
3.0 Setup	8
3.1. Probe connection	
3.2 Turning the power On / Off	
3.3. Performing a Zero adjustment	
3.4 Using Couplant (coupling fluid)	
4.0 Selecting Measuring Method and Mode	10
4.1. Measuring method	
4.2 Measuring mode	
4.3. Display format	
5.0 Measuring Method and Mode Operation Flow	11
6.0. Acoustic Velocity Adjustment	12
6.1 Acoustic velocity is known	
6.2 Acoustic velocity is unknown	
7.0 Thickness Measurement	14
7.1 Plate and sheet	
7.2 Pipes and curved surfaces	
8.0 Troubleshooting	16
9.0 Specifications	18
10.0 Principle of Thickness Measurement	19
11.0 Principle of Ultrasonic Thickness Testing	20
12.0 Glossary	22
13.0 Warranty	23

1.0 INTRODUCTION

The CHECK•LINE® TI-45NA Thickness Gauge measures the wall thickness of metals, glass, ceramics and many rigid plastics.

1.1 Delivery List

The TI-45NA is supplied as a complete kit and includes the following items:

- TI-45NA
- Probe
- Couplant (coupling fluid)
- AA-type alkaline battery
- Operating manual
- Warranty certificate
- Inspection Certificate
- Carrying case



1.2 Precautions

- The measurement results are affected by the intrinsic sound wave velocity of the material to be tested. Acoustic velocity adjustment is required before starting measurement.
- For proper measurement, the couplant fluid (contact medium) that comes with the instrument must be applied to the target surface. Applying another contact medium may damage the probe.
- Place the probe down flat on the test surface without sliding. Denting the probe surface may cause inaccurate measurement.
- Ultrasonic measurement is unsuitable for the following conditions: materials with strong ultrasonic attenuation, objects with their rear surface heavily corroded, materials containing a large proportion of foreign particles/granules and objects with poor parallelism between front and rear surfaces. (Parallelism $\pm 2^\circ$ or above)
- Acoustic velocity may vary due to ambient temperature. Without adjusting acoustic velocity, error may cause percentage of change in acoustic velocity at steel measurement is 0.0 1% per degree.
- Prolonged storage of the instrument in an extreme environment of high ambient temperature or direct sunlight may induce instrument failure.
- Remove dirt or foreign matter from the face of the target object before measuring. Measuring with the probe adhering to foreign matter may induce failure of the probe.
- The probe is a consumable item. If the instrument makes larger errors or measured data fluctuates, exchanging a probe is recommended. Probes that are scratched or damaged should also be replaced.
- Getting the main unit wet or immersed in water may cause damage.
- Avoid using the instrument in dusty or wet environments.
- Avoid hanging the instrument with the cable or twirling.
- Never try to disassemble/modify the instrument. Unauthorized disassemble/ modification will result in instrument failure. If unauthorized disassemble/ modification are found, the instrument may be no longer guaranteed. In addition, the repairs may be unacceptable.

-
-
-
- Avoid using the instrument in an environment with a strong electromagnetic field or in a corrosive gas atmosphere.
 - To protect its precisions, do not drop the instrument.
 - Avoid excessive vibration or impact.
 - Use only AA-type alkaline batteries, otherwise measurement accuracy is not guaranteed.
 - To avoid damaging the battery holder, insert the negative (-) end first, and pull out the positive (+) end first.
 - If the instrument is to be stored for a prolonged period, remove the battery to avoid liquid leakage.

2.0 OVERVIEW

2.1 Main Unit



No.	Name	Notes
1	LCD display	Measured thickness readings, sonic velocity and measuring modes are displayed.
2	Probe	A probe has dual oscillators. Take great care not to damage or abrade the surface of the probe.
3	Connector	Insert the connector to the same color on the main unit (red to red, green to green).
4	Probe Cable	Do not bend the cable. Do not bring it into contact with a high-temperature object.
5	Test plate for zero adjustment	The test plate is used for zero adjustment. 5.00mm will be displayed at acoustic velocity (5920m/s) of steel measurement.

2.2 LCD display

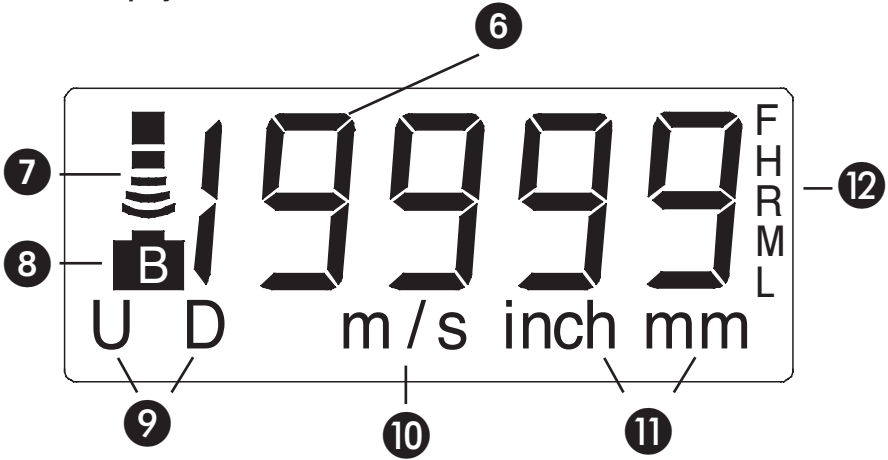

No.	Name	Notes
6	Display for thickness values, Acoustic velocity	Measured thickness value is displayed at measuring, acoustic velocity is displayed when adjusting acoustic velocity.
7	Coupling Indicator	A probe has dual oscillators. Do not damage or abrade the surface of the probe.
8	Low-battery mark	This mark is displayed when battery voltage falls below specified value.
9	Acoustic velocity adjustment	“U”&“D” will be displayed while adjusting acoustic velocity. U(UP) indicates while making acoustic velocity higher, D(DOWN) indicates while making acoustic velocity lower.
10	Unit for acoustic velocity	This is displayed while adjusting acoustic velocity.
11	Unit for thickness reading	These are units for thickness reading. “mm” and “inch” are selectable. (Refer to page 7.)
12	Measurement mode	Selected Measurement Mode and Measuring Method is displayed. (Refer to page 7.) F: FREE mode If “F” is not indicated, the instrument is on HOLD mode. H: Pipe Measurement Mode R: R-B ₁ Measurement Mode M: Standard Measurement Mode L: Aluminum Measurement Mode

2.3 Operation Panel

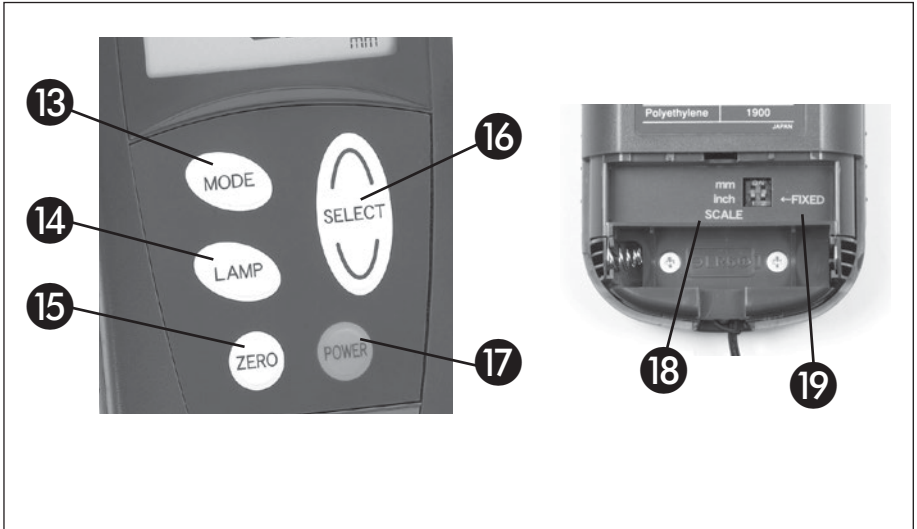

No.	Name	Notes
13	Mode Selector	Key is for selecting measuring method and measuring mode. By pressing key for 3 seconds, FREE Mode or HOLD Mode is chosen. (Refer to page 10.)
14	Back Light ON/OFF	To turn ON/OFF back light, press this key.
15	Zero adjustment key	Key is for zero adjustment. (Refer to page 8 Zero adjustment.)
16	Acoustic velocity adjustment or thickness adjustment key (Up/Down)	Push this key to adjust acoustic velocity or thickness values. (Refer to pages 12 & 13.)
17	Power button	To turn off, press this button for over 3 seconds.
18	Thickness units selector key	mm and inch are selectable.
19	PROBE selection key	Probe selection switch shall be set on the mark FIXED

3.0 MEASUREMENT SETUP



3.1 Probe connection

1. Insert the connector until you hear a clicking sound. Be sure to align the color marks (green to green and red to red).

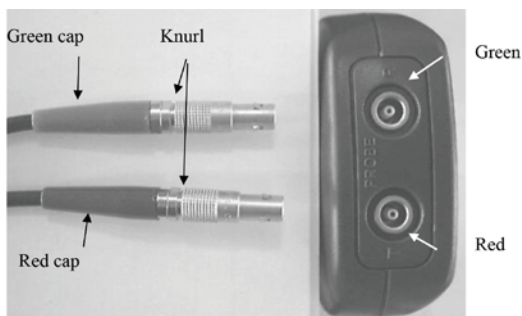
NOTE: When removing, grasp the knurled part of the connector.



3.2 Turning the power ON and OFF

1. **Turning Power ON:** Press the POWER  switch. The current acoustic velocity is displayed for two seconds. The instrument goes into Measuring Mode with LCD.
2. **Turning the power OFF:** Press and hold the POWER  switch for longer than three seconds. The instrument shuts off automatically after three minutes of non-use.





3.3 ZERO Adjustment

NOTE: Perform ZERO adjustments using the test plate on the front panel of the main unit. Memory of ZERO adjustment is stored in the instrument, but we recommend performing a ZERO adjustment once a day, preferably before starting the day's work.

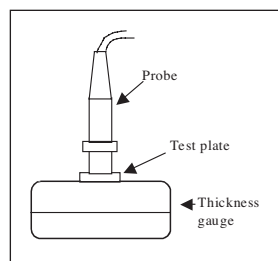
1. Apply couplant on the test plate surface and place a probe on it.
2. Make sure the probe is in good contact with the test plate surface and press the  button.
3. Zero adjustment procedure takes place and the display shows 5.00mm when the process has been successfully completed.



NOTES: When the acoustic velocity is set to a value other than 5920m/s, the display shows 5.00mm momentarily when the ZERO  button is pressed. Zero adjustment is nonetheless proceeding correctly.

Pressing the ZERO  button while measuring test material significantly larger or smaller than 5.0mm, causes the display to show four dashes and the zero adjustment process becomes invalid.



3.4 Using Couplant (coupling fluid)

1. Apply to the target surface before measurement.
2. The couplant eliminates air between the probe and test surface, promoting the transmission of the ultrasonic pulse.

NOTE: Never use organic solvents including thinners.

NOTE: Couplant is a water solution of glycerin. The surface of the probe with applying couplant for a prolonged time will give damages to the probe. The surface must be cleaned of couplant after measurement.

NOTE: Use the couplant supplied with the instrument. Using another couplant may deteriorate the probe

4.0 SELECTING MEASURING METHOD AND MODE

4.1 Measuring method



Method	Descriptions	Features	Application
S-B1 measurement method	Thickness is determined by the time difference between upper surface reflection (S-echo) and first bottom surface reflection (B1-echo)	This method, which utilizes upper surface reflection can make measurement in small errors. Our thickness gauge adopts this as standard	Upper surface reflection is strong. Ex. steel
R-B1 measurement method	This is the method to measure thickness of the material whose acoustic propagation velocity is known. This method uses a zero point predetermined after calibration thickness is determined from the time difference between the reception of first reflected pulse from the bottom (B1-echo) and this zero point.	By determination of virtual zero point, measurement can be done regardless of surface conditions of the test material. However, reasons such as temperature of probe surface etc., may cause the discrepancy between virtual zero point and actual one many increase. To avoid this, zero adjustment should be done periodically	Upper surface reflection is weak. Ex. resin

4.2 Measuring mode

Measuring Mode	Descriptions and Features	Application
Standard mode (M)	Standard sensitivity is chosen to suit the measurement of steel	Flat plate or sheet, etc.
Pipe mode (H)	High sensitivity is chosen for measurement of test object whose bottom echo is weak	Pipes, etc.
Aluminum mode (L)	Low sensitivity is chosen for stable measurement of test object with low-damping nature	Aluminum, etc.

4.3 Display format

Mode	Descriptions and Features	Application
FREE mode (F) F is shown on display	Measurement is taken once every three seconds. The last thickness value displays after you remove the probe from the material to be measured.	Cases where stable measurements can be done. Cases where many measurement times are required
HOLD mode F disappears from display	The thickness value is displayed after stabilization of measured value	When measured data is unstable..

To switch to **FREE** or **HOLD** mode: After turning the POWER on and the figures are displayed, press and hold the MODE  for 3 seconds. The instrument will be in **HOLD** mode and “F” disappears on the display (right side). Press and hold the MODE  button again, “F” will displayed and it turns to **FREE** Mode.

5.0 MEASURING METHOD AND MODE OPERATION FLOW

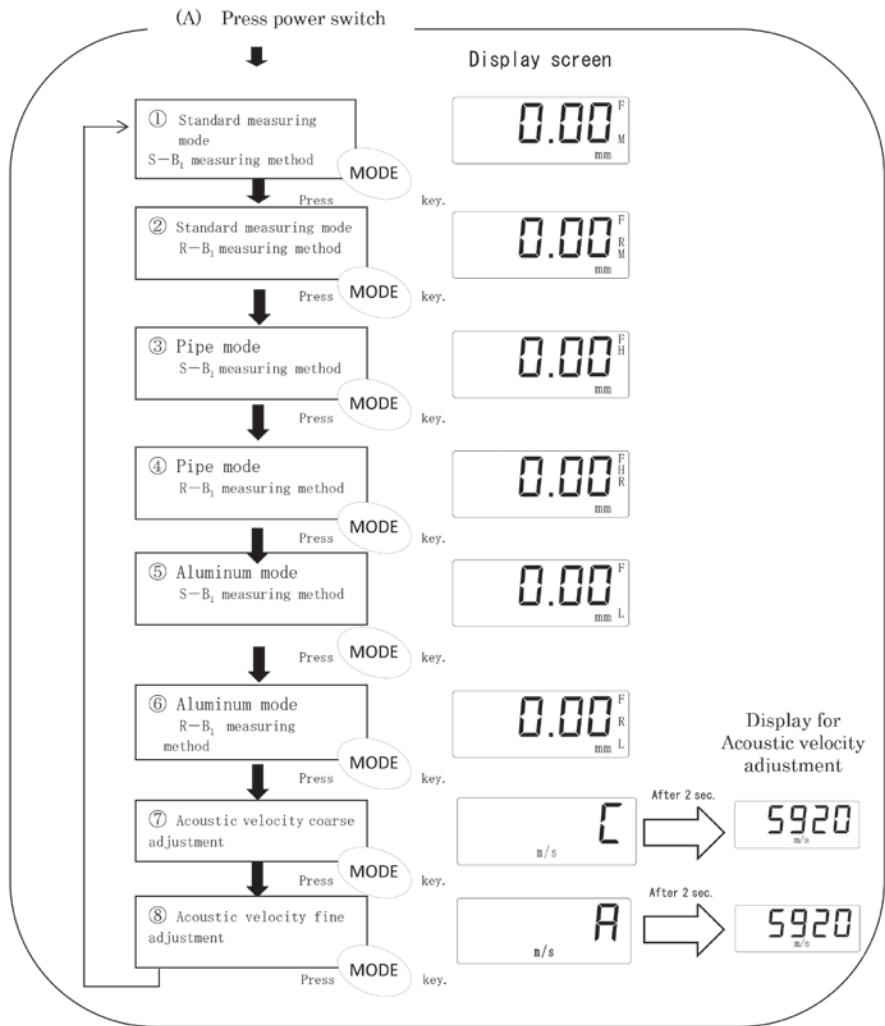

6.0 ACOUSTIC VELOCITY ADJUSTMENT



The acoustic velocity adjustment parameter is stored in the instrument and remains unchanged after turning off.

6.1 When Acoustic Velocity is Unknown

1. Measure thickness of the sample (made of some materials with the actual test material) using a micrometer or slider calipers. The value is used as a reference for subsequent measurement. (The reference sample should be selected so that its thickness value is very close to that of the actual test material. If a wide range of thickness measurement is required, prepare a reference sample with a thickness close to the upper limit of the range.)
2. Select measuring mode. See page 11, and select one method from ①, ②, ③, ④, ⑤ or ⑥
3. Apply couplant to the area where the thickness measurement has been performed by a micrometer, and put the probe into contact with it.
4. Release a probe when the reading is stabilized. In case that the setting value of acoustic velocity for the test material is wrong, the instrument indicates incorrect value.
5. Use up/down keys \curvearrowright \curvearrowleft for acoustic velocity adjustment to shift the displayed value to the reference thickness. By this procedure, acoustic velocity has been set, and then displayed value will be also changed. When displayed value completely matches reference value, acoustic velocity is setup properly.

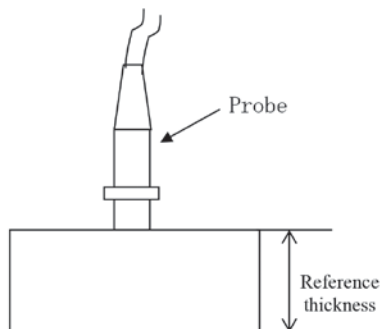

Sample(Same material with the actual test material)

Example : Reference value 10.00 mm

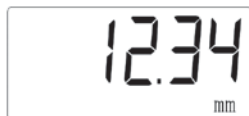

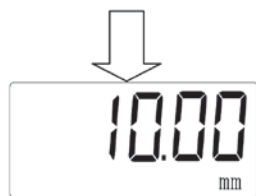

Example : 12.34 mm will display.



Adjust reading to reference thickness
(Example : 10.00mm)

Acoustic velocity adjustment is completely done.

6.1 When acoustic velocity is known



1. Select **C** using  key.
2. Use the UP/DOWN keys  to select one of the ten predefined values that is the same or close to that of the test material. Every time you press the key, one of the ten acoustic velocity values (shown below) is displayed cyclically.



Acoustic velocity (m/s)	Material	Acoustic velocity (m/s)	Material
1000	–	5570	Quartz glass
1900	Polyethylene	5790	Stainless Steel 304
2700	Acrylic	5920	Steel
4170	Zinc	6260	Aluminum
4700	Copper	10,000	–



Acoustic velocity adjustment
(Fine tuning)

3. If fine adjustment is required, use  key to select **A** and press the up/down keys  to adjust the displayed value to the actual material value. Press and hold the UP/DOWN key to accelerate the changing rate.
4. Acoustic velocity adjustment is completed. Press  key to select a suitable measuring mode display.



NOTE: Acoustic velocity adjustment parameter is stored in the instrument when returning to the measurement display by pressing the  key. Avoid turning off the POWER manually or automatically when adjusting acoustic velocity. Make sure the acoustic velocity remains unchanged. For the case stored acoustic velocity remains unchanged after turning off.

7.0 THICKNESS MEASUREMENT

7.1 Plate and sheet

Display mode setting

1. Choose display mode from **FREE** mode (F appears on the display) and **HOLD** mode (F disappears on the display). By pushing the MODE key  for 3 seconds, Mode changes alternately.

FREE mode is chosen after being turned on unless the MODE key is pressed.

In **FREE** mode, the displayed value is updated continuously at an interval of three times per second. In **HOLD** mode, the displayed value is fixed after stabilization of measured value. This is a function for easy value reading.

Preparation and measuring

2. Apply couplant to the surface of the test object and position the probe.



CAUTION

If the surface is very rough or rusty, smoothen it using emery paper etc. approx. Ra 12.5~25

3. When the instrument receives an echo signal, it displays the coupling mark  and measured value.
4. The thickness value remains displayed after removing the probe.

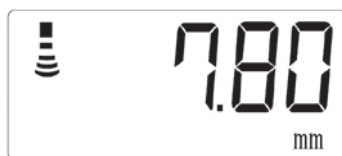
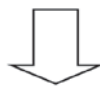
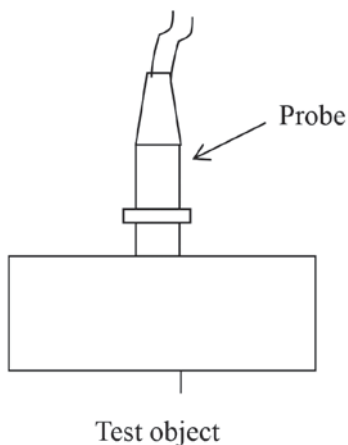

7.2 Pipes and curves surface



Position the probe so that the probe separator mark is parallel or at a right angle (90°) to the axial direction. Slanted contact may lead to an incorrect measurement.

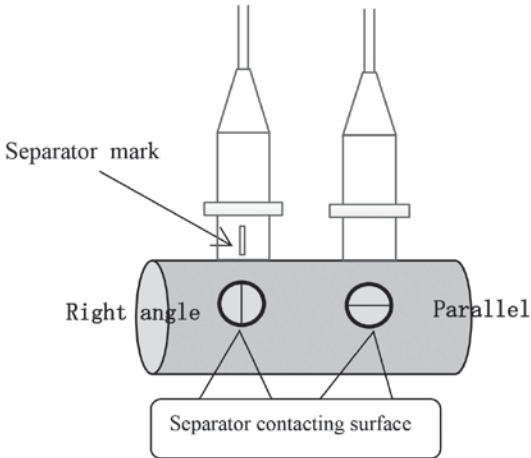



1. Place a probe perpendicular to the measuring surface and do not move it.
2. When measuring wall thickness of pipes, choose **R-B1** mode and set the acoustic separator parallel to the axial direction of the pipe. Probes have “separator mark” which indicates the position of separator. In case it is difficult to get correct values, try to use **S-B1** mode, or set acoustic separator at right angle to axial direction.
3. We recommend choosing **F (FREE)** mode for measuring pipes. Inappropriate probe positioning on curved surfaces may lead to an inaccurate measurement. It is possible to make the instrument indicate this incorrect value, by holding that incorrect value under inappropriate probe holding.
4. Optional attachments are available for stable measurement on curved surfaces.



TI-P01A

8.0 TROUBLESHOOTING

Problem	Possible Cause	Remedy
TI-45NA thickness gauge does not turn on.	<ol style="list-style-type: none"> 1. Dry battery is not set, or inappropriate battery is set. 2. Dry battery is set in the opposite direction(+/-) 3. Dry battery is weak 4. Dry battery leaked. 	<ol style="list-style-type: none"> 1. Set AA alkaline battery. 2. Set dry battery correctly. 3. Set new battery. 4. Remove dry battery after use, for long storage. Please contact the dealer or us directly, if you find battery leakage.
Coupling mark  is blinking	<ol style="list-style-type: none"> 1. External noise is too strong. (Ex. Using near electric discharge machine) 2. Probe deteriorated. 	<ol style="list-style-type: none"> 1. Use TI-45NA thickness gauge at points where noise is weak. 2. Contact the dealer or us directly.
TI-45NA displays — at zero adjustment procedure	<ol style="list-style-type: none"> 1. The test piece for zero adjustment is not adequate. 2. Probe or probe cable deteriorated. 	<ol style="list-style-type: none"> 1. Retry zero adjustment with adequate test piece (5mm) thickness, if it is steel. 2. Contact the dealer or us directly.
TI cannot measure or Coupling Indicator does not appear at measuring. 	<ol style="list-style-type: none"> 1. Quantity of couplant is not sufficient. 2. Surface of test material is too rough. 3. Bottom surface of test material is too rough. 4. Ultrasonic wave attenuates by inner structure of test material. 5. Test material thickness is out of measuring range. 6. Probe cable is not correctly connected. 7. Probe (or probe cable) is damaged or deteriorated. 	<ol style="list-style-type: none"> 1. Apply sufficient amount of couplant. 2. Grind or polish the surface of test material. Use sander or emery paper to finish the surface at level of Ra12.5-Ra25 3. Choose another measuring point. 4. Choose another measuring point or set measuring mode at HOLD mode. (Refer to Page 10) 5. Use TI-45NA within measurable range. 6. Connect firmly and correctly to match color of connector and port. 7. Contact the dealer or us directly.
Measured values are not stable	<ol style="list-style-type: none"> 1. There is strong noise (ex. There is electric discharge machine near the tester) 2. To measure thickness of curved surface, there is some point in the measuring method or test material is out of measuring range 3. Probe is damaged or deteriorated 	<ol style="list-style-type: none"> 1. Use the instrument in a place where noise is weak. 2. Take an appropriate way to measure curved surface, refer to 7.2 Measuring pipes or curved surface. 3. Contact the dealer or us directly.

Problem	Possible Cause	Remedy
There is too big an error.	<ol style="list-style-type: none"> 1. Zero adjustment is not done. 2. Acoustic velocity setting value is not correct. 3. Test material has a curved surface (ex. small diameter pipe). 4. There are inclusions or uneven structure inside the test material. 5. There is a layer of paint or coating. 6. Probe is deteriorated 7. The connected probe is inappropriate or the setting of probe selection switch is wrong. 	<ol style="list-style-type: none"> 1. Execute zero adjustment before measurement. 2. Set appropriate acoustic velocity for test material. 3. Take an appropriate way to measure curved surface, refer to 7.2 Measuring pipes or curved surface. Please check if test material is within the measuring range. 4. Change measuring point to avoid errors caused by ultrasonic wave reflection from inclusions or uneven structure inside the test material 5. Layer of paint or coating may disturb measurement. Retry after removing the layer. 6. Renew the probe. 7. Connect appropriate probe Or set probe selection switch correctly (Refer to page 7).
	Mode selection is wrong. (Is standard mode or Pipe measuring mode chosen? Choose aluminum mode.)	Choose aluminum mode.
Measured values are unstable or not indicated at measuring resin.	S-B ₁ method is chosen	Choose R-B ₁ method.
Measured values are not indicated a measuring pipes.	Standard mode or aluminum mode is chosen.	Choose pipe mode Choose pipe mode at measuring aluminum.

9.0 SPECIFICATIONS

Range (steel)	Flat Plate: 0.040" to 8.000" (<i>1.00 to 199.99mm</i>) Pipe/Tubes: Wall Thickness from 0.060" (<i>1.50mm</i>) and greater Diameter of 1.070" (<i>27.2mm</i>) and larger
Repeatability	± 0.001" (<i>0.02mm</i>)
Accuracy	± 0.002", 0.040" to 4.000" (<i>0.05mm, 1.00 to 99.00mm</i>) ± 2% of Reading, 4.000 to 8.000" (<i>100.00 to 199.99mm</i>)
Resolution	0.001" (<i>0.01mm</i>)
Probe	10mm to 5 MHz Dual-Element Transducer (p/n 5Z10NDT-M) supplied with 1 meter length connecting cable (39")
Material	Iron, Steel, Aluminum, Stainless Steel, some other metals as well as some plastics, glass and ceramics
Acoustic Velocity	1,000 to 12,000 m/sec with 10 predefined acoustic velocities stored in gauge
Display	Digital LCD Display with backlight
Display Frequency	Approx. 3 times/sec
Digits	4-1/2 (max 19999) the upper digit displays 1 only
Start-up Time	Approx 2 Sec.
Power Supply	1 AA-type alkaline battery, 1.5 V
Operating Time	>30 hours continuous operation Usage: 2 sec. measurement followed by 10 sec standby
Test Plate for Zero Adjustment	5.00mm thickness for steel (Acoustic Velocity 5920 m/s)
Weight	Meter: 5.4 oz (<i>150g</i>) Probe: 1.8 oz (<i>50g</i>)
Dimensions	5.7 x 2.7 x 1.2" (<i>144 x 69 x 30mm</i>)
Operating Temp	23 to 122°F (<i>-5 to 50°C</i>)
Storage Temp	14 to 131°F (<i>-10 to 55°C</i>)
Warranty	Meter: 1 Year Probe: 90 Days

PRINCIPLE OF THICKNESS MEASUREMENT

Probe Structure

The probe structure is shown below. Transmitter oscillators are dual purpose parts that send out ultrasonic waves and simultaneously receive reflected waves from the upper surface of test object (S-echo). Receiver oscillators receives reflected waves from the bottom of the test object (B-echo).

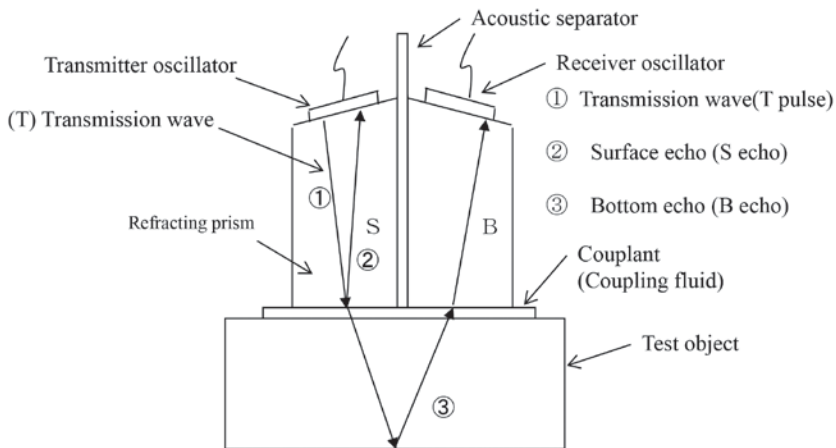

Parts	Function
Transmitter oscillator	The transmitter oscillator transmits ultrasonic waves (T pulse) by impressing voltage. It also receives echos from the surface of the test object (S-echo).
Receiver oscillator	The receiver oscillator receives echos from the bottom of test object (B-echo) and transforms them into voltage.
Acoustic separator	The acoustic separator prevents direct access of ultrasonic waves from the transmitter oscillator
Refracting prism	The oscillators are sent on the angled top surface of the refracting prism, which allows ultrasonic waves pass through linearly.
Couplant	Couplant eliminates air from the space between probe and test object, preventing obstruction of the ultrasonic wave. Apply couplant on surface of test object before checking thickness.

PRINCIPLE OF ULTRASONIC TESTING

The TI-45NA uses the pulse reflection method which measures thickness by calculating the time interval it takes an ultrasonic wave to go and return from the object

The diagram shown below explains this process.

Some parts of the ultrasonic wave ① sent from the transmitter oscillator are reflected at the surface of the test object and become results surface echo ② . Some parts of the ultrasonic wave which penetrate into the test object are reflected by the bottom surface and results in the bottom echo (B). Ultrasonic wave travelling time can be checked by counting pulses between S-echo and B-echo, if pulses are generated in a fixed interval.

Time between detections of S-echo and B-echo is represented in an equation shown below which can be utilized to measure object thickness:

$$D = \frac{1}{2} C \times t$$

D: thickness of object (m)

t: Travelling time for going and returning (s)

C: Intrinsic acoustic propagation velocity of material (M/s)

Ultrasonic thickness gauges measure thickness from acoustic propagation velocity of material (C) and time interval (t) between S-echo and B-echo, and indicate thickness value on the display. It is required to set correct acoustic propagation velocity to achieve a correct measurement.

Block Diagram

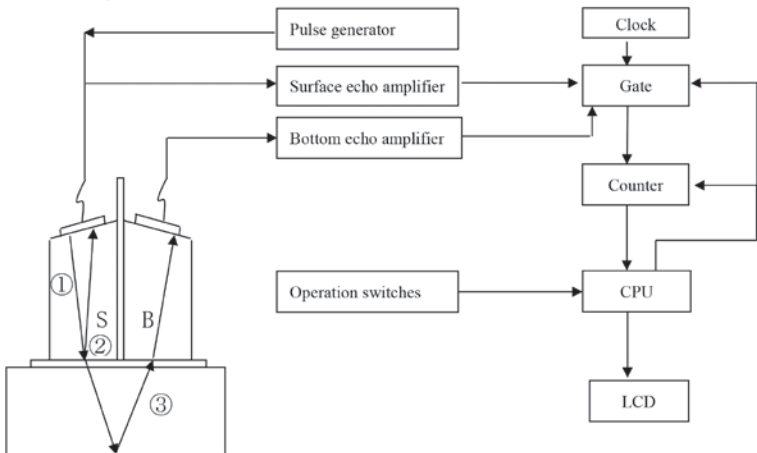

① ...Transmission wave(T pulse) ②...Surface echo(S echo)

③ ...Bottom echo(B eco)

Waveform time chart (S-B₁ method)

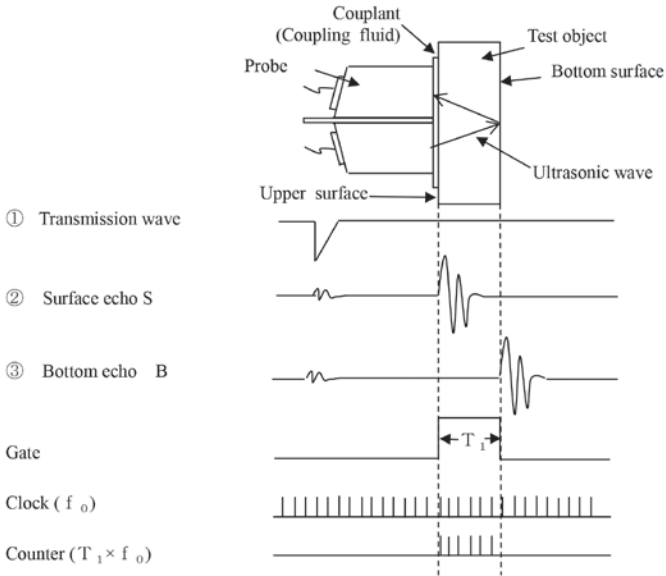

(R-B₁ method)

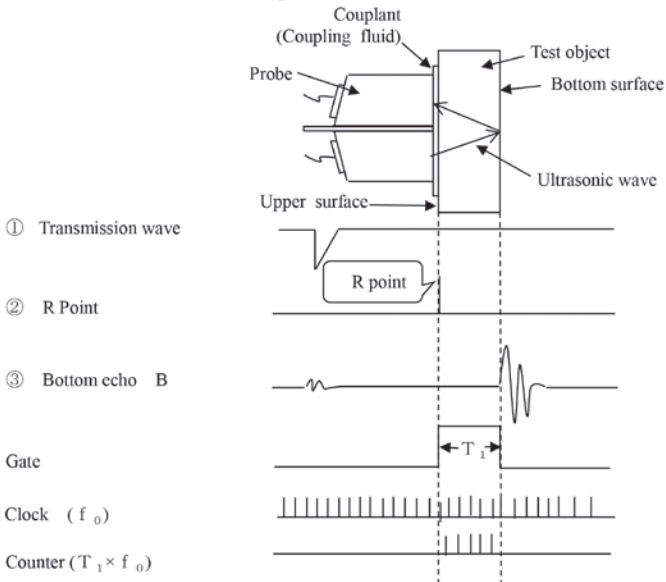

13.0 GLOSSARY

Acoustic velocity adjustment: Acoustic velocity varies depending upon the material. The correct acoustic velocity must be set for accurate thickness measurement.

Coupling indicator: A symbol that appears on the LCD display when the ultrasonic echo is being properly received.

Probe: A sensor that emits an ultrasonic pulse to the object to be measured and receives a reflected echo from it.

Coupling fluid: Contact medium (water solution of glycerin) that fills the space between the probe and the surface to be measured, securing good ultrasonic transmission by displacing air.

WARRANTY

ELECTROMATIC Equipment Co., Inc. (ELECTROMATIC) warrants to the original purchaser that this product is of merchantable quality and confirms in kind and quality with the descriptions and specifications thereof. Product failure or malfunction arising out of any defect in workmanship or material in the product existing at the time of delivery thereof which manifests itself within one year from the sale of such product, shall be remedied by repair or replacement of such product, at ELECTROMATIC's option, except where unauthorized repair, disassembly, tampering, abuse or misapplication has taken place, as determined by ELECTROMATIC. All returns for warranty or non-warranty repairs and/or replacement must be authorized by ELECTROMATIC, in advance, with all repacking and shipping expenses to the address below to be borne by the purchaser.

THE FOREGOING WARRANTY IS IN LIEU OF ALL OTHER WARRANTIES, EXPRESSED OR IMPLIED, INCLUDING BUT NOT LIMITED TO, THE WARRANTY OF MERCHANTABILITY AND FITNESS FOR ANY PARTICULAR PURPOSE OR APPLICATION. ELECTROMATIC SHALL NOT BE RESPONSIBLE NOR LIABLE FOR ANY CONSEQUENTIAL DAMAGE, OF ANY KIND OR NATURE, RESULTING FROM THE USE OF SUPPLIED EQUIPMENT, WHETHER SUCH DAMAGE OCCURS OR IS DISCOVERED BEFORE, UPON OR AFTER REPLACEMENT OR REPAIR, AND WHETHER OR NOT SUCH DAMAGE IS CAUSED BY MANUFACTURER'S OR SUPPLIER'S NEGLIGENCE WITHIN ONE YEAR FROM INVOICE DATE.

Some State jurisdictions or States do not allow the exclusion or limitation of incidental or consequential damages, so the above limitation may not apply to you. The duration of any implied warranty, including, without limitation, fitness for any particular purpose and merchantability with respect to this product, is limited to the duration of the foregoing warranty. Some states do not allow limitations on how long an implied warranty lasts but, notwithstanding, this warranty, in the absence of such limitations, shall extend for one year from the date of invoice.

ELECTROMATIC Equipment Co., Inc.
600 Oakland Ave. Cedarhurst, NY 11516—USA
Tel: 1-800-645-4330/ Tel: 516-295-4300/ Fax: 516-295-4399

Every precaution has been taken in the preparation of this manual. Electromatic Equipment Co., Inc., assumes no responsibility for errors or omissions. Neither is any liability assumed for damages resulting from the use of information contained herein. Any brand or product names mentioned herein are used for identification purposes only, and are trademarks or registered trademarks of their respective holders.



ELECTROMATIC

E Q U I P M E N T C O . , I N C .

600 Oakland Ave., Cedarhurst, NY 11516 – USA
TEL: 516-295-4300 • FAX: 516-295-4399