

# **Wireless Light Sensor and 3-Phase Current Meter**

## **R718NL3 User Manual**

## Table of Content

1. Introduction .....	2
2. Appearance .....	3
3. Main Features .....	3
4. Set up Instruction .....	4
5. Data Report .....	5
6. Installation .....	9
7. Information about Battery Passivation .....	12
7.1 To determine whether a battery requires activation .....	12
7.2 How to activate the battery .....	12
8. Important Maintenance Instruction .....	13

## 1. Introduction

The R718NL3 series is a Light Sensor and 3-Phase Current Meter device for Netvox ClassA type devices based on the LoRaWAN open protocol and is compatible with the LoRaWAN protocol. R718NL3 series have different measuring range for different variety of CT.

It is divided into:

**R718NL3** Wireless Light Sensor and 3-Phase Current Meter with 3 x 50A Solid Core CT

(Range:100mA-50A , Accuracy  $\pm 1\%$  within 300mA~50A)

**R718NL37** Wireless Light Sensor and 3-Phase Current Meter with 3 x 75A Clamp-On CT

(Range: 100mA -75A  $\pm 1\%$ , Accuracy  $\pm 1\%$  within 300mA~50A)

**R718NL315** Wireless Light Sensor and 3-Phase Current Meter with 3 x 150A Clamp-On CT (Range:1A-150A  $\pm 1\%$ )

**R718NL325** Wireless Light Sensor and 3-Phase Current Meter with 3 x 250A Clamp-On CT (Range:1A-250A  $\pm 1\%$ )

**R718NL363** Wireless Light Sensor and 3-Phase Current Meter with 3 x630A Clamp-On CT (Range:10A-630A  $\pm 1\%$ )

\* When the current of the device that is 75A or below is less than 100mA, the current is reported as 0.

When the current of the device that is above 75A is less than 1A, the current is reported as 0.

### LoRa Wireless Technology

LoRa is a wireless communication technology famous for its long-distance transmission and low power consumption. Compared with other communication methods, LoRa spread spectrum modulation technique greatly extend the communication distance. It can be widely used in any use case that requires long-distance and low-data wireless communications. For example, automatic meter reading, building automation equipment, wireless security systems, industrial monitoring. It has features like small size, low power consumption, long transmission distance, strong anti-interference ability and so on.

### LoRaWAN

LoRaWAN uses LoRa technology to define end-to-end standard specifications to ensure interoperability between devices and gateways from different manufacturers.

## 2. Appearance



R718NL3

R718NL37

R718NL315



R718NL325



R718NL363

## 3. Main Features

- Compatible with LoRaWAN protocol
- 2 sections ER14505 3.6V Lithium AA battery
- Simple operating and setting
- Protection level : Main body IP53, Sensor IP30
- Compatible with LoRaWAN™ Class A
- Frequency hopping spread spectrum technology
- Configuration parameters can be configured through third-party software platforms, data can be read and alarms can be set via SMS text and email (optional)
- Available third-party platform: Actility / ThingPark, TTN, MyDevices/Cayenne
- Low power consumption and long battery life

Note:

Battery life is determined by the sensor reporting frequency and other variables, please refer to

[http://www.netvox.com.tw/electric/electric\\_calc.html](http://www.netvox.com.tw/electric/electric_calc.html)

On this website, users can find battery life time for varied models at different configurations.

## 4. Set up Instruction

### On/Off

Power on	Insert batteries. (users may need a flat blade screwdriver to open)
Turn on	Press and hold the function key for 3 seconds till the green indicator flashes once.
Turn off (Restore to factory setting)	Press and hold the function key for 5 seconds till green indicator flashes 20 times.
Power off	Remove Batteries.
Note	<p>1.The device will be off after removing the battery and insert it again.</p> <p>2.It is suggested to wait for at least 10 seconds between turning the device on and off.</p> <p>3.At 1<sup>st</sup> -5<sup>th</sup> second after power on, the device will be in engineering test mode.</p>

### Network Joining

If the device has never joined the network	<p>Turn on the device, and it will search for the network to join.</p> <p>The green indicator light stays on for 5 seconds: joins the network successfully</p> <p>The green indicator light remains off: fail to join the network</p>
If the device has joined the network and it is not set to default	<p>Turn on the device, and it will search for the previous network to join.</p> <p>The green indicator light stays on for 5 seconds: joins the network successfully</p> <p>The green indicator light remains off: fail to join the network</p>
If the device fails to join the network (when the device is turned on)	<p>Note: It is suggested to remove the batteries if the device is not in use to save power.</p> <p>It is suggested to check the device verification information on the gateway or consult your platform server provider when the device fails to join the network.</p>

### Function Key

Press the function key and hold the pressing for 5 seconds	<p>The device will be set to default and turned off</p> <p>The green indicator light flashes 20 times: success</p> <p>The green indicator light remains off: fail</p>
Press the function key once	<p>The device is in the network: green indicator light flashes once and sends a report</p> <p>The device is not in the network: green indicator light remains off</p>

### Sleeping Mode

The device is turned on and in the network	<p>Sleep period: Min Interval.</p> <p>When the reportchange exceeds setting value or the state changes: send a data report according to Min Interval.</p>
The device is turned on but not in the network	<p>Note: Suggest to remove batteries if the device is not used.</p> <p>Suggest to check device verification on gateway.</p>

## Low Voltage Warning

Low Voltage	3.2V
-------------	------

## 5. Data Report

The device will immediately send a version packet report along with an uplink packet including current, illuminance and battery voltage.

The device sends data in the default configuration before any configuration is done.

### Default setting:

Maximum time: Max Interval =15 min (900 s)

Minimum time: Min Interval =15 min (900 s) \*Please configure more than 30 seconds

CurrentChange:0x0064 (100 mA) (Subject to factory settings)

IlluminanceChange: 0x0064 (100 Lux) (Subject to factory settings)

### Light sensor support 3 ranges of Illuminance:

0x00, 3~65000 Lux (default)

0x01, 3~130000 Lux

0x02, 3~220000 Lux

### Note:

- (1) The device report interval will be programmed based on the default firmware which may vary.
- (2) The interval between two reports must be the minimum time.
- (3) If MinTime configuration less than 30 seconds, it will configure 30 seconds.
- (4) R718NL3 series would take about 15 seconds for the CT to sample and process the collected value, If the current changes frequently, the sampling result might be wrong.

Please refer Netvox *LoRaWAN Application Command document* and *Netvox Lora Command Resolver*

<http://loraresolver.netvoxcloud.com:8888/page/index> to resolve uplink data.

Data report configuration and sending period are as following:

Min. Interval (Unit:second)	Max. Interval (Unit:second)	Reportable Change	Current Change $\geq$ Reportable Change	Current Change $<$ Reportable Change
Any number between 30~65535	Any number between Min.~65535	Can not be 0.	Report per Min. Interval	Report per Max. Interval

### Example of Report configuration

FPort: 0x07

Bytes	1 Byte	1 Byte	Var(Fix =9 Bytes)
	CmdID	DeviceType	NetvoxPayLoadData

**CmdID**– 1 byte

**DeviceType**– 1 byte – Device Type of Device

**NetvoxPayLoadData**– var bytes (Max=9bytes)

Description	Device	Cmd ID	Device Type	NetvoxPayLoadData					
ConfigReport Req	R718NL3	0x01	0x99	MinTime (2bytes Unit:s)	MaxTime (2bytes Unit:s)	CurrentChange (2byte Unit:1mA)	Illuminancechange (2bytes Unit:1Lux)	Reserved (1Bytes, Fixed 0x00)	
ConfigReport Rsp		0x81		Status (0x00_success)			Reserved (8Bytes,Fixed 0x00)		
ReadConfig ReportReq		0x02		Reserved (9Bytes,Fixed 0x00)					
ReadConfig ReportRsp		0x82		MinTime (2bytes Unit:s)	MaxTime (2bytes Unit:s)	CurrentChange (2byte Unit:1mA)	Illuminancechange (2bytes Unit:1Lux)	Reserved (1Bytes, Fixed 0x00)	

(1) Configure report parameters MinTime = 1min, MaxTime = 1min, CurrentChange = 100mA, IlluminanceChange = 100Lux

Downlink: 0199003C003C0064006400

The device returns:

81990000000000000000 (Configuration succeeded)

81990100000000000000 (Configuration failed)

(2) Read device configuration parameters

Downlink: 02990000000000000000

The device returns:

8299003C003C0064006400 (current device configuration parameters)

**Report Current and Illuminance Data Example**

R718NL3	0x99	0x01	Battery (1Byte, unit:0.1V)	Current1 (2Bytes, Unit:1ma)	Current2 (2Bytes, Unit:1ma)	Current3 (2Bytes, Unit:1ma)	Multplier1 (1Byte), the real current1 should convert with Current* Multplier
		0x02	Battery (1Byte, unit:0.1V)	Multplier2(1Byte), the real current2 should convert with Current* Multplier	Multplier3 (1Byte), the real current3 should convert with Current* Multplier	Illuminance (4Bytes, Unit:1Lux)	Reserved (1Bytes, fixed 0x00)

FPort 6 Report Data (1): 01990124 03E8 03E8 03E8 01

(2): 01990124 01 01 00000003 00

Current1=Current1\*Multplier1、 Current2=Current2\*Multplier2、 Current3=Current3\*Multplier3

When illuminance less than 3 lux, the reported value is 3 lux.

**Example for MinTime/MaxTime logic**

**Example#1** based on MinTime = 1 Hour, MaxTime= 1 Hour, Reportable Change i.e. BatteryVoltageChange=0.1V

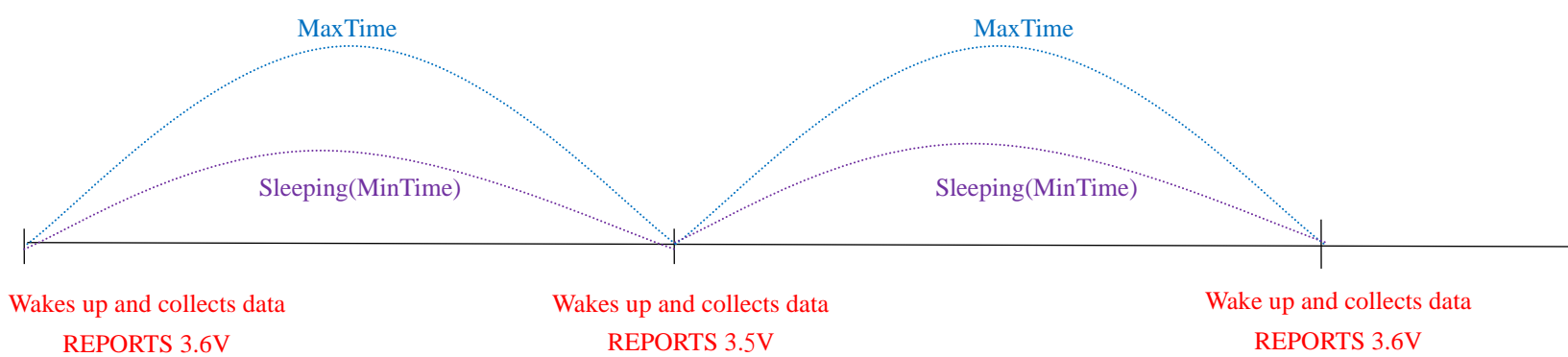

Note: MaxTime=MinTime. Data will only be report according to MaxTime (MinTime) duration regardless BatteryVoltageChange value.



**Example#2** based on MinTime = 15 Minutes, MaxTime= 1 Hour, Reportable Change i.e. BatteryVoltageChange= 0.1V.

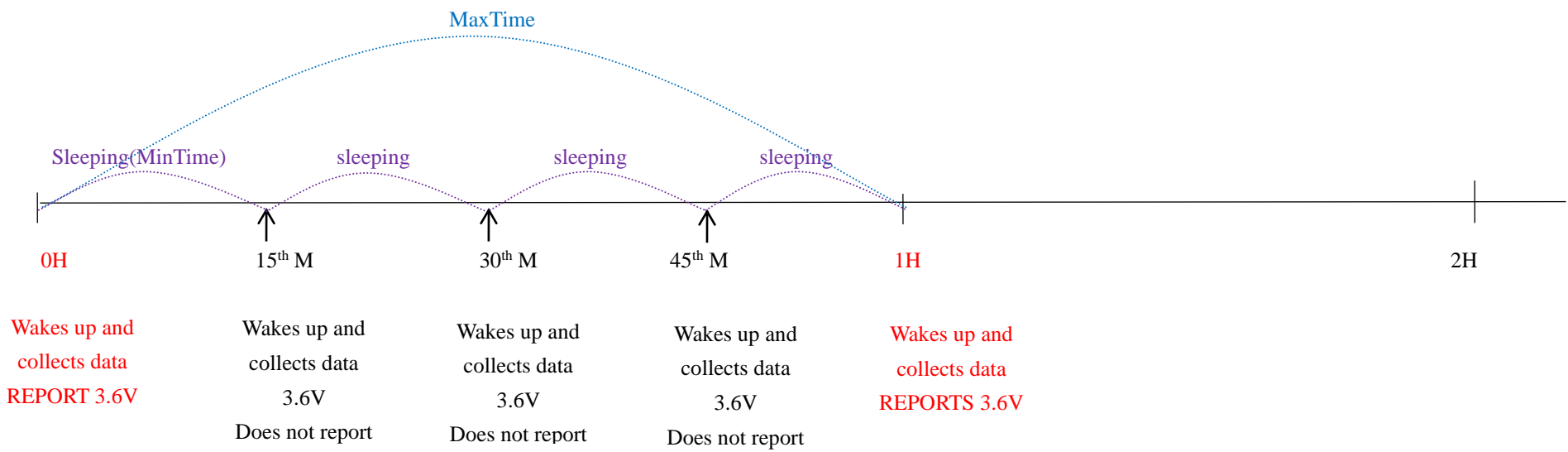

**Example#3** based on MinTime = 15 Minutes, MaxTime= 1 Hour, Reportable Change i.e. BatteryVoltageChange= 0.1V.

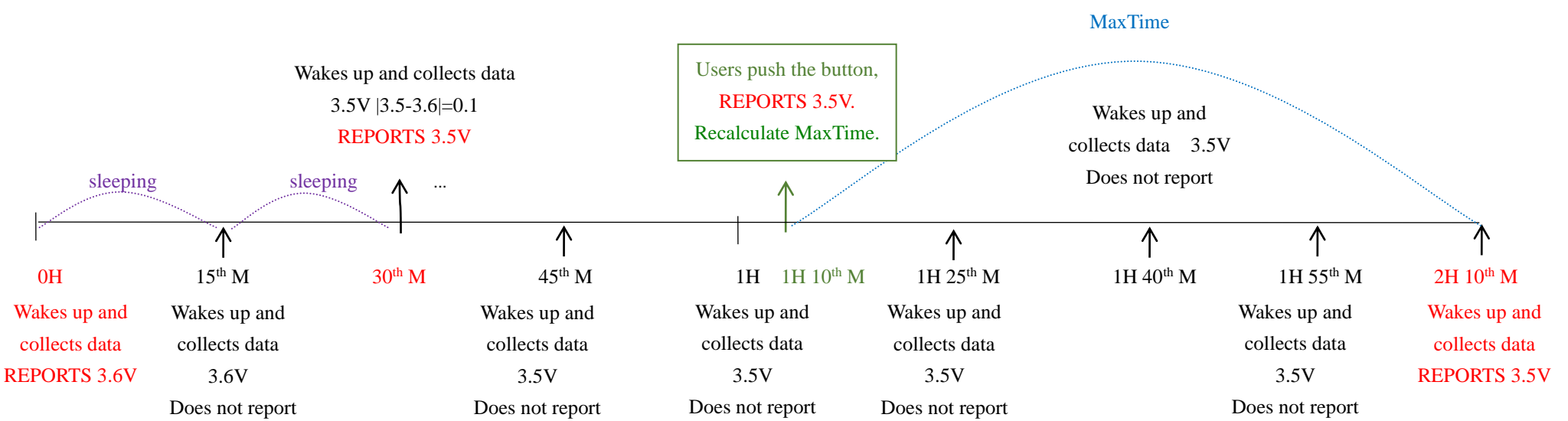

Notes :

- 1) The device only wakes up and performs data sampling according to MinTime Interval. When it is sleeping, it does not collect data.
- 2) The data collected is compared with the last data reported. If the data variation is greater than the ReportableChange value, the device reports according to MinTime interval. If the data variation is not greater than the last data reported, the device reports according to MaxTime interval.
- 3) We do not recommend to set the MinTime Interval value too low. If the MinTime Interval is too low, the device wakes up frequently and the battery will be drained soon.
- 4) Whenever the device sends a report, no matter resulting from data variation, button pushed or MaxTime interval, another cycle of MinTime/MaxTime calculation is started.

## 6. Installation

1. When using it, the back of it can be adsorbed on the iron surface, or the two ends can be fixed to the wall with screws.
2. When installing the R718NL3 series current transformer, please separate the live and neutral wires of the wire to be detected, and only take the live wire through current transformer and start the measurement according to the wiring below:

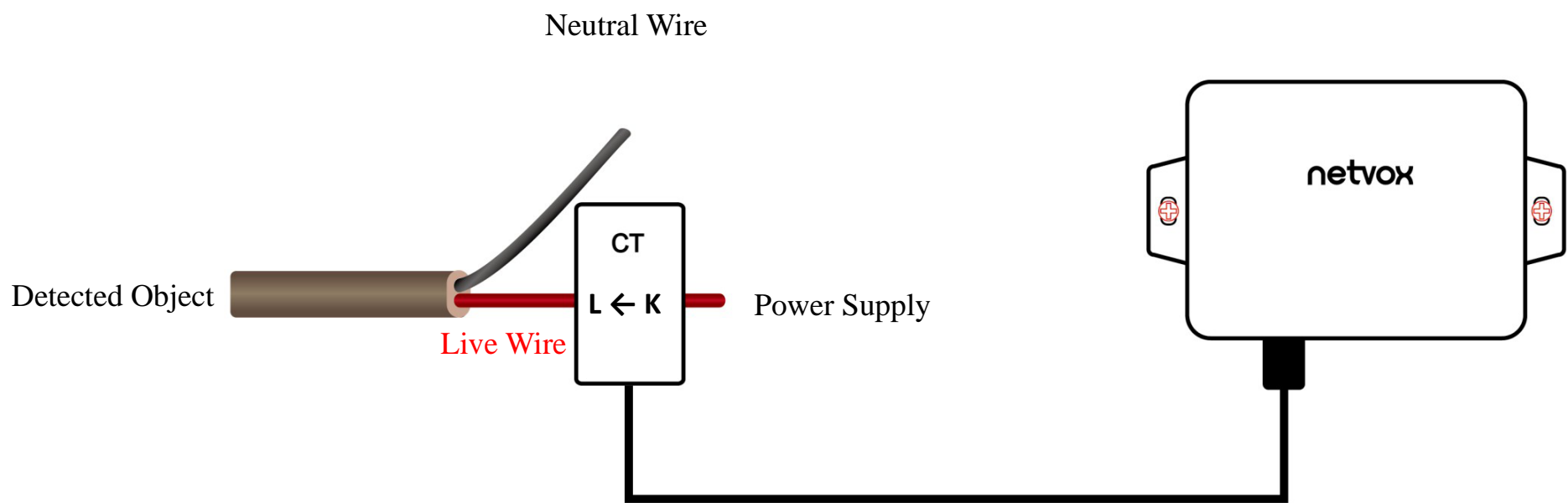

CT Wiring Schematic Diagram (Current direction K→L)

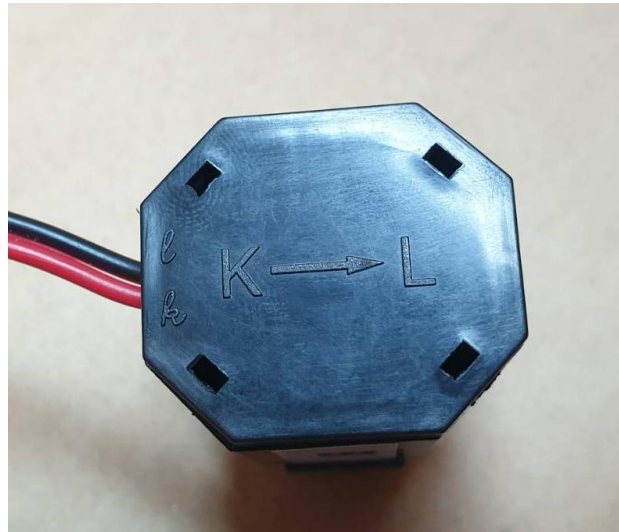

If the live wire and the neutral wire are connected together at the same time, they will offset each other and the measurement is 0.

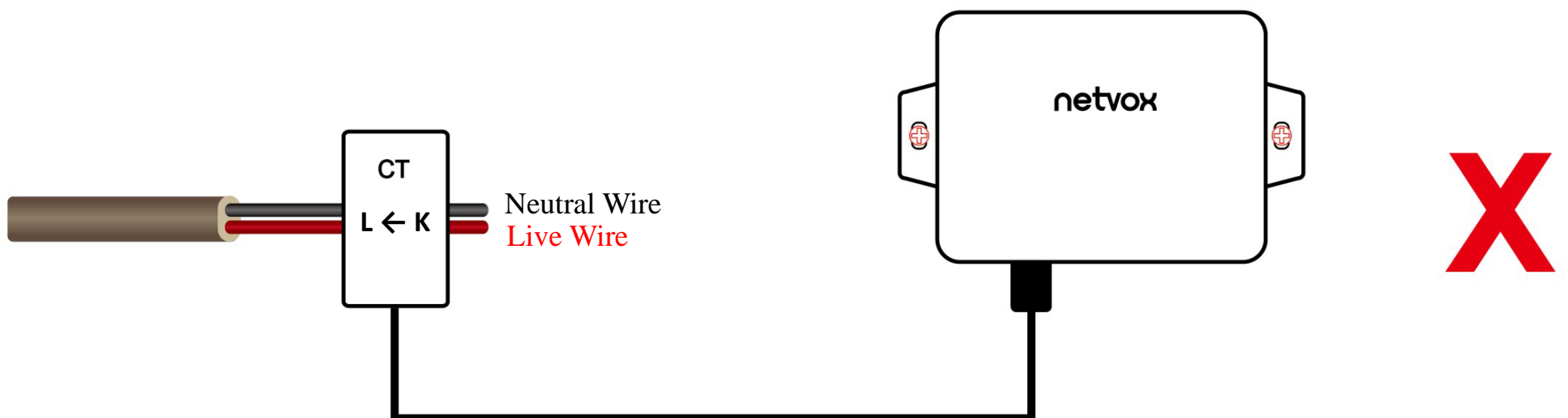

1. The single-phase current detector (R718NL3) has a built-in magnet (as the figure below). It can be attached to the surface of an object with iron during installation, which is convenient and quick.

To make the installation more secure, please use screws (purchased separately) to fix the device to the wall or other objects (such as the installation diagram).

Note: Do not install the device in a metal shielded box or in an environment surrounded by other electrical equipment to avoid affecting the wireless transmission of the device.

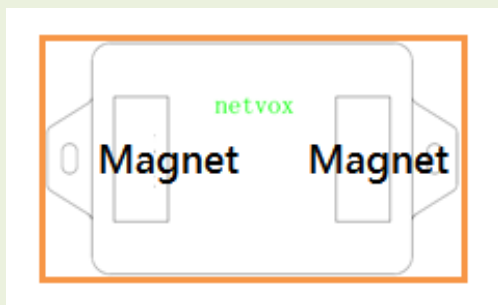

4. The three-phase current detector (R718NL3) samples the current according to MinTime. If the current value sampled this time relatively exceeds the set value (the default is 100mA) more than the current value reported last time, the device will immediately report the current value sampled this time. If the current variation does not exceed the default value, the data will be reported regularly according to MaxTime.

Press the [Key] of the device to start sampling data and report the data after 3 to 5 seconds.

Note: MaxTime must be set greater than Min Time.

2. Open the split current transformer, and then pass the live wire through the current transformer according to the installation.

Note:

"L←K" is marked on the bottom of the CT.

3. Precautions:

- Before using, user must check whether the appearance is deformed; otherwise, the test accuracy will be affected.
- The using environment should be kept away from strong magnetic fields, so as not to affect the test accuracy. It is strictly forbidden to use in humid and corrosive gas environments.
- Before installation, please confirm the current value of the load. If the current value of the load is higher than the measurement range, select a model with a higher measurement range.

The three-phase current detector (R718NL3) is suitable for the following scenarios:

- School
- Factory
- Shopping mall
- Office building
- Smart building

Where the electrical data of the equipment with the three-phase electricity needs to be detected.

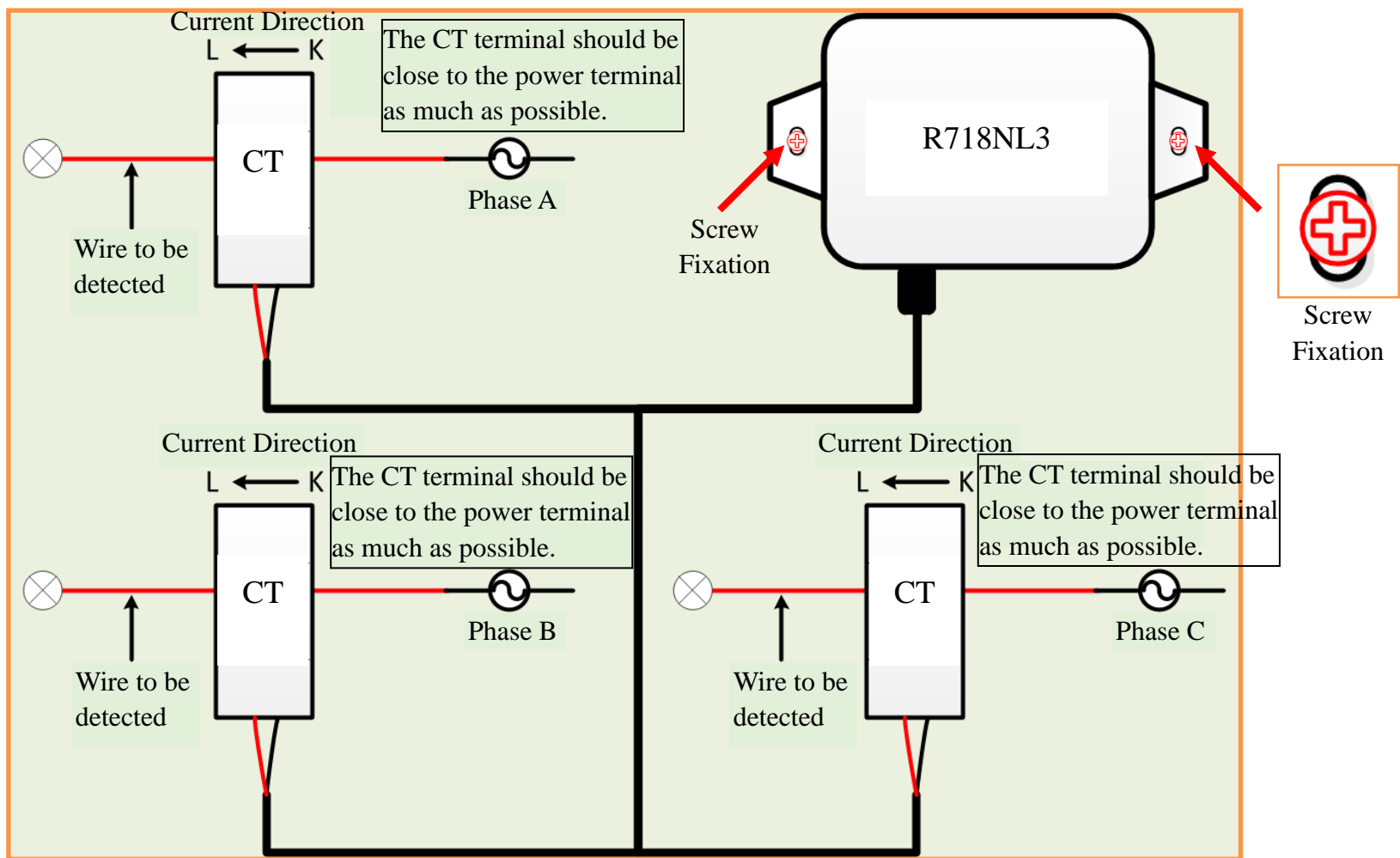

Installation Diagram

Note:

Please do not disassemble the device unless it is required to replace the batteries.

Do not touch the waterproof gasket, LED indicator light, function keys when replacing the batteries. Please use suitable screwdriver to tighten the screws (if using an electric screwdriver, it is recommended to set the torque as 4kgf) to ensure the device is impermeable.

## 7. Information about Battery Passivation

Many of Netvox devices are powered by 3.6V ER14505 Li-SOCl<sub>2</sub> (lithium-thionyl chloride) batteries that offer many advantages including low self-discharge rate and high energy density.

However, primary lithium batteries like Li-SOCl<sub>2</sub> batteries will form a passivation layer as a reaction between the lithium anode and thionyl chloride if they are in storage for a long time or if the storage temperature is too high. This lithium chloride layer prevents rapid self-discharge caused by continuous reaction between lithium and thionyl chloride, but battery passivation may also lead to voltage delay when the batteries are put into operation, and our devices may not work correctly in this situation.

As a result, please make sure to source batteries from reliable vendors, and it is suggested that if the storage period is more than one month from the date of battery production, all the batteries should be activated.

If encountering the situation of battery passivation, users can activate the battery to eliminate the battery hysteresis.

### ER14505 Battery Passivation:

#### 7.1 To determine whether a battery requires activation

Connect a new ER14505 battery to a resistor in parallel, and check the voltage of the circuit.

If the voltage is below 3.3V, it means the battery requires activation.

#### 7.2 How to activate the battery

- a. Connect a battery to a resistor in parallel
- b. Keep the connection for 5~8 minutes
- c. The voltage of the circuit should be  $\geq 3.3$ , indicating successful activation.

Brand	Load Resistance	Activation Time	Activation Current
NHTONE	165 $\Omega$	5 minutes	20mA
RAMWAY	67 $\Omega$	8 minutes	50mA
EVE	67 $\Omega$	8 minutes	50mA
SAFT	67 $\Omega$	8 minutes	50mA

Note:

If you buy batteries from other than the above four manufacturers, then the battery activation time, activation current, and required load resistance shall be mainly subject to the announcement of each manufacturer.

## 8. Important Maintenance Instruction

Kindly pay attention to the following in order to achieve the best maintenance of the product:

- Keep the device dry. Rain, moisture, or any liquid might contain minerals and thus corrode electronic circuits. If the device gets wet, please dry it completely.
- Do not use or store the device in dusty or dirty environment. It might damage its detachable parts and electronic components.
- Do not store the device under excessive heat condition. High temperature can shorten the life of electronic devices, destroy batteries, and deform or melt some plastic parts.
- Do not store the device in places that are too cold. Otherwise, when the temperature rises to normal temperature, moisture will form inside, which will destroy the board.
- Do not throw, knock or shake the device. Rough handling of equipment can destroy internal circuit boards and delicate structures.
- Do not clean the device with strong chemicals, detergents or strong detergents.
- Do not apply the device with paint. Smudges might block in the device and affect the operation.
- Do not throw the battery into the fire, or the battery will explode. Damaged batteries may also explode.

All of the above applies to your device, battery and accessories.

If any device is not working properly, please take it to the nearest authorized service facility for repair.